

Series MD pressure regulators

Ports with interchangeable cartridges: threaded (1/8, 1/4, 3/8) or integrated with super-rapid fitting for tube with \varnothing 6, 8 and 10 mm
Versions: single, combined with other functions, Manifold



- » Minimal pressure decreases
- » Knob with position lock
- » Tamper-proof system (lockable regulator)
- » With or without overpressure exhaust (relieving)
- » Available versions: Manifold, with by-pass valve, calibrated, locked.

Thanks to the flexibility given by the connection inserts, the regulator can be adjusted within a treatment group so that the regulation knob is in the front or lower position. Once the regulation is locked, it is possible to insert as many security locks through the 4 holes.

The by-pass valve allows the fast exhaust of the air introduced.

The different springs enable a more accurate adjustment of the pressure.

The Series MD offers multi-sector solutions that ensure saving in terms of installation time, space and costs. Thanks to the solution adopted for the pneumatic connection, it is possible to equip the same element with interchangeable cartridges that can either be threaded, or with an integrated super-rapid fitting, both types available in different sizes. Intermediate cartridges can be also integrated to join multiple functions or with derivation to draw air.

GENERAL DATA

Construction	modular, compact with pre-formed diaphragm
Materials	see TABLE OF MATERIALS on the following page
Ports	with interchangeable cartridges: 1/8, 1/4 and 3/8 threaded or integrated with super-rapid fitting for tube with \varnothing 6, 8 and 10 mm
Fixing	in-line; wall-mounting by means of through holes in the body or with a support bracket; panel mounting
Operating temperature	-5°C ÷ 50°C up to 16 bar
Inlet pressure	0 ÷ 16 bar
Outlet pressure	0 ÷ 2 bar 0 ÷ 4 bar 0.5 ÷ 7 bar 0.5 ÷ 10 bar
Overpressure exhaust	with relieving without relieving
Nominal flow	see FLOW DIAGRAMS on the following pages
Fluid	compressed air

CODING EXAMPLE

MD	1	-	R	T	0	0	-	1/4	-	■	-	●
-----------	----------	----------	----------	----------	----------	----------	----------	------------	----------	----------	----------	----------

MD	SERIES
1	SIZE: 1 = 42 mm
R	TYPE OF REGULATOR: R = pressure regulator M = Manifold pressure regulator
T	OPERATING PRESSURE (1 bar = 14,5 psi): 0 = 0,5 ÷ 10 bar 2 = 0 ÷ 2 bar 4 = 0 ÷ 4 bar 7 = 0.5 ÷ 7 bar T = calibrated ** B = locked **
0	DESIGN TYPE: 0 = with relieving 1 = without relieving 2 = with relieving and by-pass valve (only for R regulator) 3 = without relieving, with by-pass valve (only for R regulator)
0	PRESSURE GAUGE: 0 = without pressure gauge (with 1/8 port)
1/4	PORTS (IN - OUT)*: = without cartridges 1/8 = G1/8 1/4 = G1/4 3/8 = G3/8 6 = tube Ø6 8 = tube Ø8 10 = tube Ø10 * NOTE: if the inlet (IN) cartridge is different from the outlet (OUT) cartridge, both dimensions shall be indicated. Example: MD1-R020-1/4-10
<p>** NOTE: IF THE REGULATOR IS CALIBRATED OR LOCKED, AFTER THE PORTS ADD THE INLET PRESSURE "■" AND THE OUTLET PRESSURE "●"</p> <p>INLET PRESSURE: ■ = enter the SUPPLY pressure value</p> <p>OUTLET PRESSURE: ● = enter the OUTLET pressure value for the LOCKED regulator or the maximum value of the ADJUSTABLE pressure for the CALIBRATED regulator</p> <p>Example of a calibrated regulator with Inlet Pressure = 6.3 bar and Outlet Pressure = 4.5 bar Complete part number: MD1-RT00-1/4-6.3-4.5</p>	

SERIES MD REGULATORS

Pressure regulators Series MD - materials

R = pressure regulator
M = Manifold pressure regulator

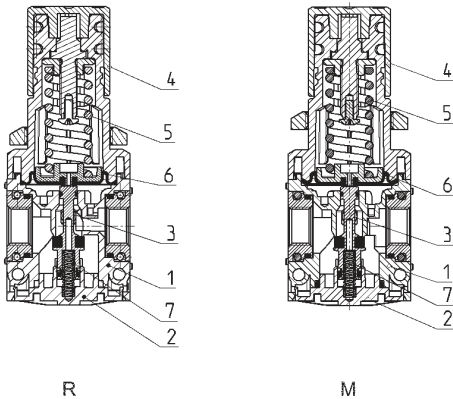

PARTS	MATERIALS
1 = Body	Polyamide
2 = Valve holder plug	Polyamide
3 = Poppet	Brass
4 = Knob	Polyamide
5 = Upper spring	Zinc-plated steel
6 = Diaphragm	NBR
7 = Lower spring	Stainless steel
Seals	NBR

FLOW DIAGRAMS for regulators with working pressures of 2, 4, 7, 10 bar

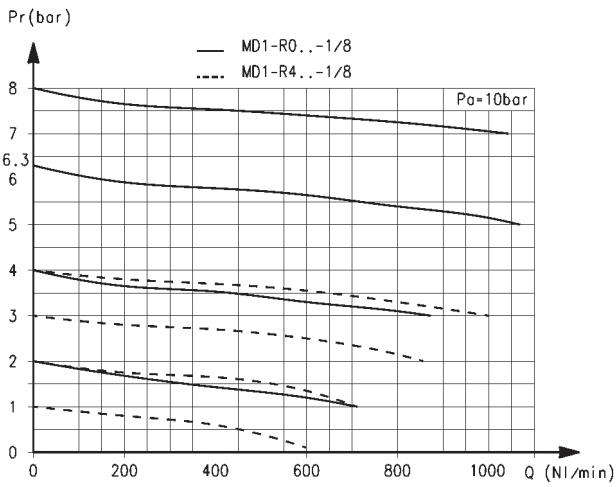

Ports with interchangeable 1/8 threaded cartridges

Pr = Regulated pressure (bar)
Q = Flow (NI/min)

Pa = Inlet pressure (bar)

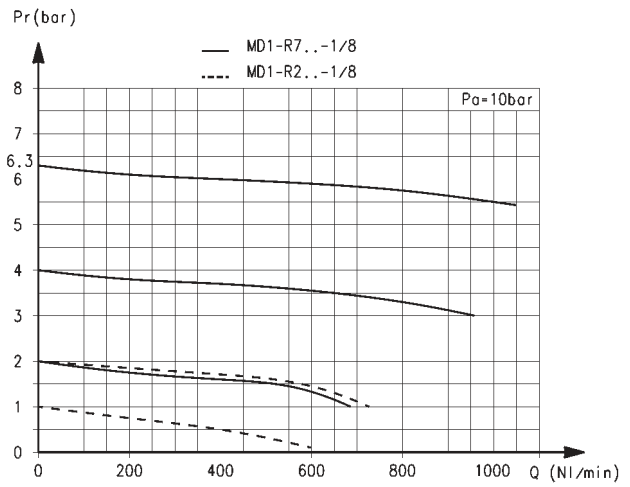

Ports with interchangeable 1/8 threaded cartridges

Pr = Regulated pressure (bar)
Q = Flow (NI/min)

Pa = Inlet pressure (bar)

FLOW DIAGRAMS for regulators with working pressures of 2, 4, 7, 10 bar

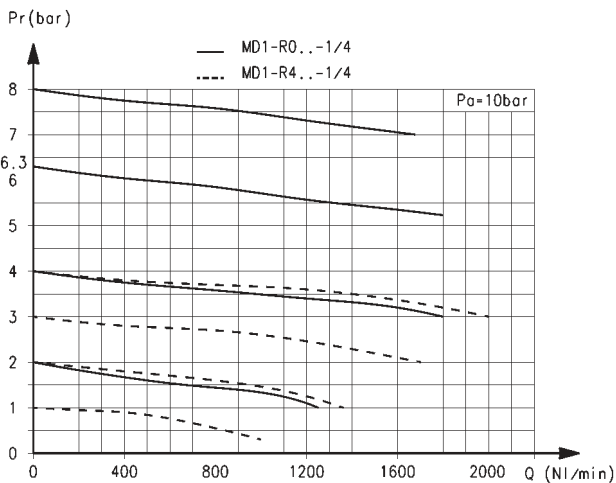

Ports with interchangeable 1/4 threaded cartridges

Pr = Regulated pressure
Q = Flow

Pa = Inlet pressure

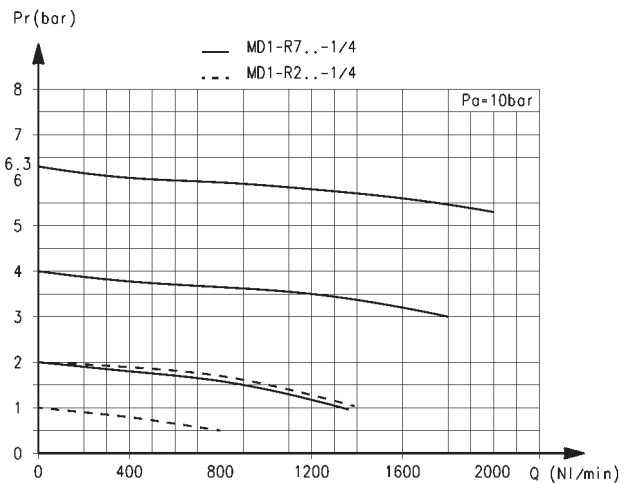

Ports with interchangeable 1/4 threaded cartridges

Pr = Regulated pressure
Q = Flow

Pa = Inlet pressure

FLOW DIAGRAMS for regulators with working pressures of 2, 4, 7, 10 bar

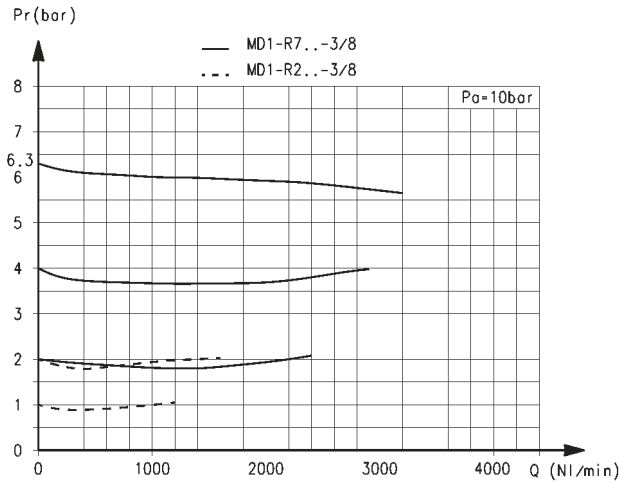
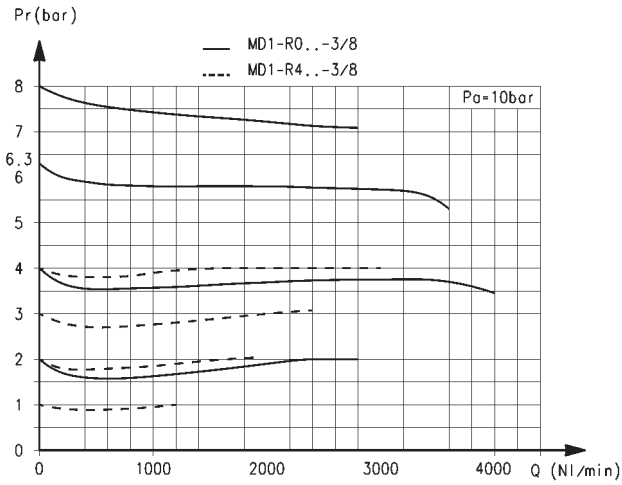

Ports with interchangeable 3/8 threaded cartridges

Pr = Regulated pressure (bar)
Q = Flow (NI/min)

Pa = Inlet pressure (bar)

Ports with interchangeable 3/8 threaded cartridges

Pr = Regulated pressure (bar)
Q = Flow (NI/min)

Pa = Inlet pressure (bar)

Series MD pressure regulators - dimensions



- PR01 = regulator without relieving
- PR02 = regulator with relieving
- PR03 = regulator with relieving and by-pass valve
- PR04 = regulator without relieving and with by-pass valve

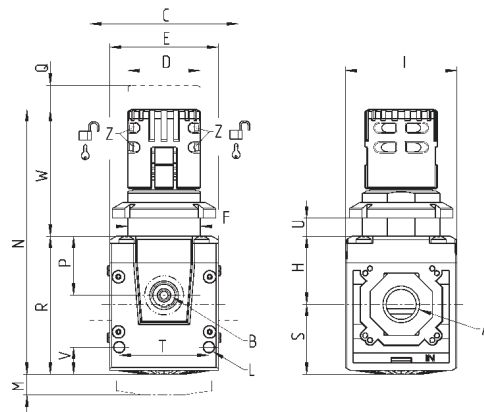
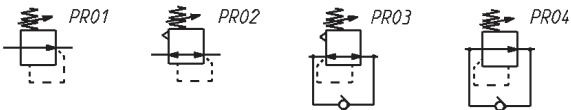

Mod.	A	B	C	D	E	F	H	I	L	M	N	P	Q	R	S	T	U	V	W	Z	Weight (Kg)
MD1-R000	-	G1/8	42	Ø28	42	M28X1,5	26.2	43	Ø4	16	102	22.7	4	53.2	27	34.6	0 ± 11	10.5	48.8	Ø3.2	0.2
MD1-R000-1/8	G1/8	G1/8	42	Ø28	42	M28X1,5	26.2	43	Ø4	16	102	22.7	4	53.2	27	34.6	0 ± 11	10.5	48.8	Ø3.2	0.2
MD1-R000-1/4	G1/4	G1/8	42	Ø28	42	M28X1,5	26.2	43	Ø4	16	102	22.7	4	53.2	27	34.6	0 ± 11	10.5	48.8	Ø3.2	0.2
MD1-R000-3/8	G3/8	G1/8	42	Ø28	42	M28X1,5	26.2	43	Ø4	16	102	22.7	4	53.2	27	34.6	0 ± 11	10.5	48.8	Ø3.2	0.2
MD1-R000-6	Ø6	G1/8	47	Ø28	42	M28X1,5	26.2	43	Ø4	16	102	22.7	4	53.2	27	34.6	0 ± 11	10.5	48.8	Ø3.2	0.2
MD1-R000-8	Ø8	G1/8	62	Ø28	42	M28X1,5	26.2	43	Ø4	16	102	22.7	4	53.2	27	34.6	0 ± 11	10.5	48.8	Ø3.2	0.2
MD1-R000-10	Ø10	G1/8	67	Ø28	42	M28X1,5	26.2	43	Ø4	16	102	22.7	4	53.2	27	34.6	0 ± 11	10.5	48.8	Ø3.2	0.2

FLOW DIAGRAMS for Manifold regulators with working pressures of 2, 4, 7, 10 bar

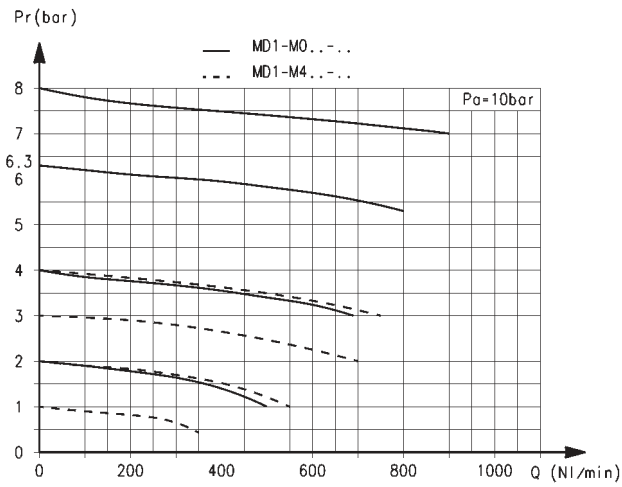

Pr = Regulated pressure (bar)
Q = Flow (NI/min)
Pa = Inlet pressure (bar)

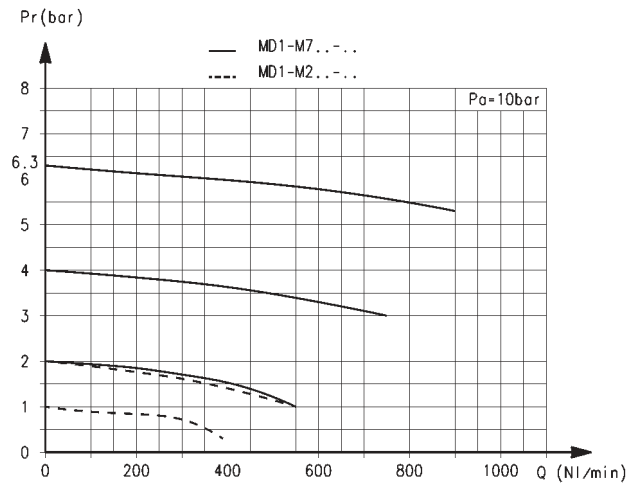

Pr = Regulated pressure (bar)
Q = Flow (NI/min)
Pa = Inlet pressure (bar)

MANIFOLD REGULATOR - PNEUMATIC SYMBOLS

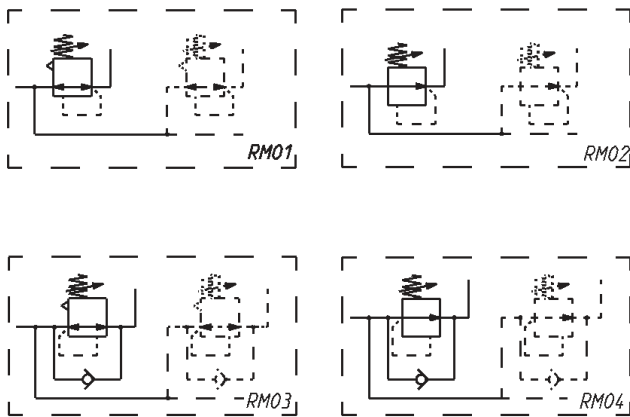

RM01 = Manifold regulator with relieving
RM02 = Manifold regulator without relieving
RM03 = Manifold regulator with relieving and by-pass valve
RM04 = Manifold regulator without relieving, with by-pass valve

Series MD pressure regulators - dimensions



With the Manifold version it is possible to realize a battery of regulators which are fed by a single source of inlet pressure. Each regulator can be set up at any pressure (lower than the inlet pressure). The front or rear connection of each regulator allows to draw air at the pressure value set on the regulator itself.

There is no limit to the number of regulators that can be connected.

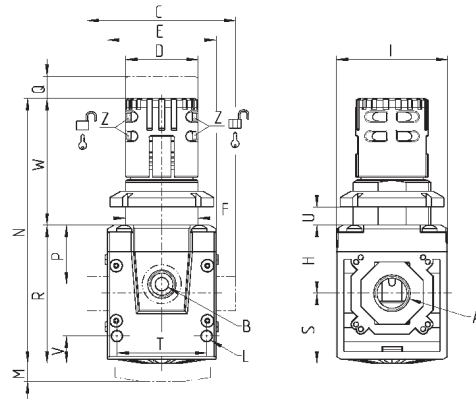

SERIES MD REGULATORS

Mod.	A	B	C	D	E	F	H	I	L	M	N	P	Q	R	S	T	U	V	W	Z	Weight (Kg)
MD1-M000	-	G1/8	42	Ø28	42	M28X1,5	26.2	43	Ø4	16	102	22.7	4	53.2	27	34.6	0 ± 11	10.5	48.8	Ø3.2	0.2